

AURO® SPOT Z 300

LED SPOT MOVING HEAD



FEATURES

- ▶ Compact spot moving head with 7,500 lm luminous flux
- ▶ 10° to 25° zoom range
- ▶ Extremely even light dispersion free of hotspots
- ▶ Automatic position correction
- ▶ Motorised focus
- ▶ 2 gobo wheels, 6 rotating gobos (indexable and exchangeable) and 6 fixed gobos + open
- ▶ Continuously adjustable color wheel with 8 intense colors + open
- ▶ Indexable and rotating 5-facet linear and 6-facet circular prisms
- ▶ 4 programmable macros for standalone and master-slave operation
- ▶ Soft frost filter for washlight effects
- ▶ Flicker-free for use in TV, film and photo studios
- ▶ Battery-powered 6-button display for offline configuration

DESCRIPTION

With fantastic gobo projections, morphing and mid-air effects, the Cameo AURO® SPOT Z 300 is made for impressive lighting design. Compact yet fully featured, the RDM-enabled spot moving head offers both a 540° and 630° pan and a 270° tilt with 16-bit resolution and automated position correction. The 10° to 25° zoom range facilitates both short- and long-range projections, which remain pin sharp at all times thanks to the motorised focus.

The AURO® SPOT Z 300 is fitted with an extremely bright 200-watt cold-white LED. It is flicker-free and distinguishes itself with incredibly even light dispersion without any hotspots. A continuously adjustable color wheel with eight brilliant colors, two prisms, two gobo wheels, six indexable and rotating exchangeable gobos and six fixed gobos means that the moving head is ideally equipped for exciting, professional performances.

The AURO® SPOT Z 300 can be controlled via DMX or be automated. Featuring freely programmable macros, it can be used as a standalone or operated in master/slave mode. DMX functions include rapid strobe, gobo shake and smooth dimming. Cooling and silent operation are provided by a temperature-controlled fan in robust housing made with ABS and metal. 3- and 5-pin DMX connections and powerCON-compatible power sockets permit convenient daisy chaining, while the battery-powered 6-button display allows power-independent configuration. The AURO® SPOT Z 300 comes with a power cable and two Omega brackets.



Features and specifications
subject to change without notice.

adamhall.com

AURO[®] SPOT Z 300

LED SPOT MOVING HEAD



PHOTOMETRICAL DATA

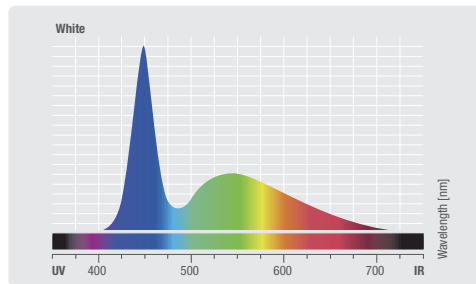
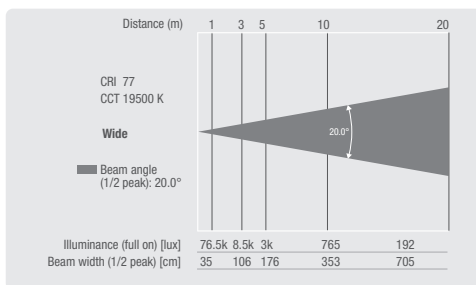
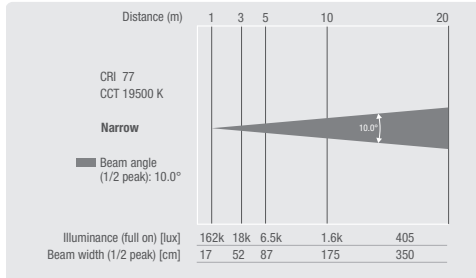

SPECIFICATIONS

Product type	LED Moving Lights
Type	Moving Head
Color spectrum	Cold white
Number of LEDs	1
LED type	200 W
Refresh rate	12000 Hz, 2000 Hz, 25000 Hz, 800 Hz, 1200 Hz, 3600 Hz
Dispersion	10 - 25 °
Number of colors	Infinitely rotatable color wheel with 8 colors + white
DMX input	XLR 3-pin male, XLR 5-pin male
DMX output	XLR 3-pin female, XLR 5-pin female
DMX mode	20-channel, 17-channel
DMX Functions	2 x Prism, Auto programs, Device Settings, Dimmer, Focus, Gobo Rotation, Gobo wheel, Pan/Tilt, Pan/Tilt fine, Rotation Gobo Wheel, Color wheel, Frost, Gobo Shake, Motion Macro, strobe
PAN movement	540° / 630°
TILT movement	270°
Standalone modes	Auto programs, Master / Slave mode, User macros
Control	DMX512, RDM enabled
Controls	4 x Arrow keys, Enter, Mode
Indicators	Backlit color LCD display, Battery supply for mains-independent system settings (automatically rechargeable battery)
Operating voltage	100 V AC - 240 V AC, 50 - 60 Hz
Power consumption	320 W
Fuse	T4AL250V (5 x 20 mm)
Operating Temperature	0 - 40 °C
Relative Humidity	< 85 %, not condensing
Power connector	Neutrik powerCON IN / OUT
Housing material	ABS plastic, metal
Cabinet color	Black
Illuminance	162000 lx @ 1 m
Luminous flux	7500 lm
Width	282 mm
Height	469 mm
Depth	186 mm
Weight	11.2 kg
Accessories (included)	2 x omega mounting, 1 m power cable with Neutrik powerCON connector included

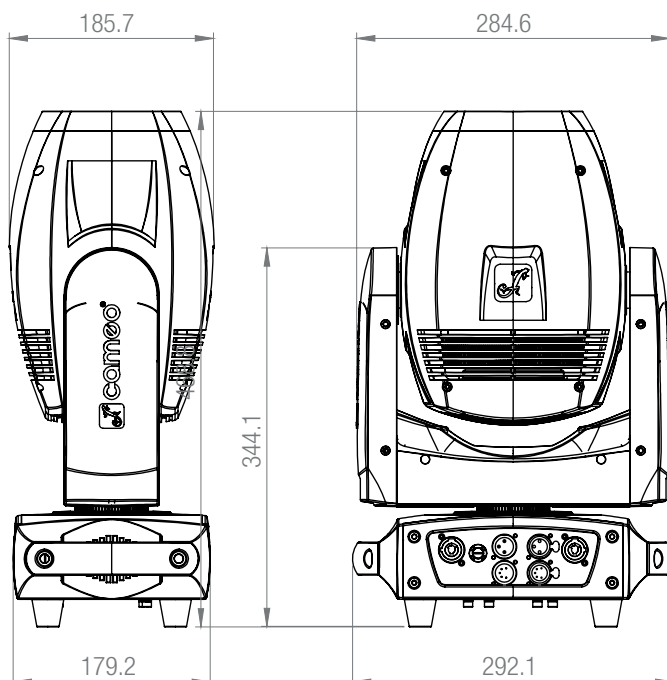

Features and specifications subject to change without notice.

adamhall.com